

1"-11 1/2" 1 1/4"-11 1/2" 1 1/2"-11 1/2" 2"-11 1/2"

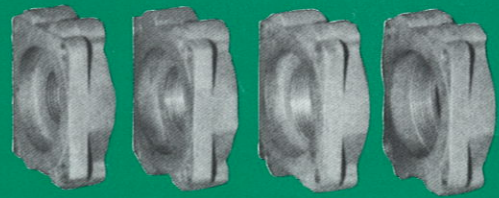

1 5/16"-12 1 5/8"-12 1 7/8"-12 2 1/2" -12

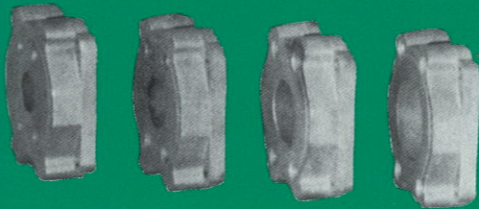

1" 1 1/4" 1 1/2" 2"

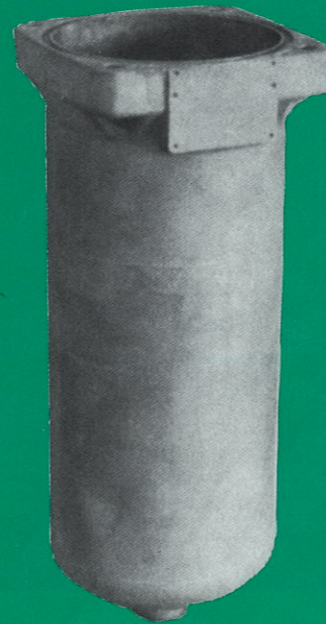

MARVELINE TB® SERIES FEATURES

- Rugged Die Cast Aluminum Construction
- Optional Visual or Electric Indicators
- Extra-Large Flow Area Integral By-Pass Valve
- Optional Marvelmag® Magnetic Filtration
- Wide Selection of Media Including Synthetic Media
- Optional 1/8-27 NPTF Gage Ports
- Fluorocarbon Seals Available
- Mix and Match Port Sizes to Fit YOUR Needs

1400 PSIG (96.5 Bars) Minimum Burst @ 70°F (21.1°C)
 Cleanable Media Elements from 30 Mesh to 10 Micron.
 Disposable Media Elements from 100 Micron to 0.60 Micron
 300°F (148.9°C) Maximum Operating Temperature

"T" Type Filter with Bolted Housing and Bolt-On Port Adapters

350 PSIG (24.1 Bars) Maximum Operating Pressure

Flows to 175 GPM (662 LPM).



How To Order Marveline TB® Series Filter

1. Insure Operating Pressure does not exceed 350 PSIG (24.1 Bars)
2. Examine pressure drop versus flow curves (page 5). For desired media select standard, extended or double length filter element and housing.
3. Examine Fluid Table (next page) and determine fluid group.
4. Select housing length from Table I to match selected element length and fluid group. Insert this number into housing assembly number (see below).
5. Select port size and style number from Table II and insert into housing assembly number.
6. Select housing option(s) letter(s) from Table III and insert into housing assembly number.
7. Select by-pass valve option from Table IV and insert into housing assembly number.
8. Select element length prefix number from Table V and insert into element assembly number.
9. Select element option(s) from Table VI and insert into element assembly number.
10. Select media suffix number from Table VII and insert into element assembly number.
11. Select optional visual or electric indicator part number from Table VIII and insert into optional indicator number.

EXAMPLE

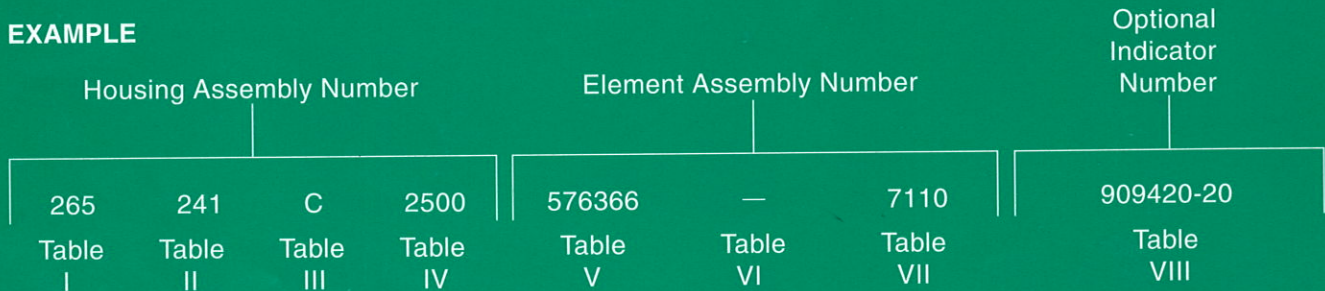

NOTE: THE EXAMPLE TB FILTER IS STANDARD LENGTH HOUSING, 11/2" NPTF PORTS, HEAD MACHINED FOR OPTIONAL INDICATOR, 25 PSI BY-PASS, STANDARD LENGTH ELEMENT, 10 MICRON MEDIA W/O ELEMENT OPTIONS, AND 20 PSI VISUAL COLORGAGE INDICATOR. I. E. 265241-C-2500/576366-7110/909420-20 IS COMPLETE MODEL NUMBER FOR ORDERING.

Marveline TB® Accessories
See Tables VI and VIII for Ordering



MARVEL COLORGAGE® INDICATOR

Filter element condition indicator combines reliable "pressure-differential" operating principle with attention-compelling Color Bands (Green, Yellow, Red-as unmistakable as traffic lights) to clearly pre-warn of element clogging. Available integrally mounted on filter head (as illustrated in drawings) or subplate mounted for remote or panel usage.

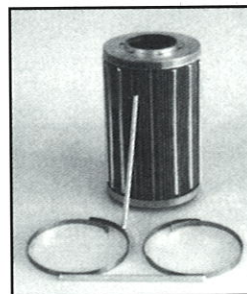

MARVELMAG® MAGNETIC FILTER SHIELD

So easy to service! "Lay-in...Lift-out" Magnetic rods. MarvelMag Shield is formed by individual magnetic rods placed in grooves on outer surface of element. To clean rods, just lift out, wipe off, and lay them back in grooves. Slip-on spring clip keeps rods from being dislodged accidentally.

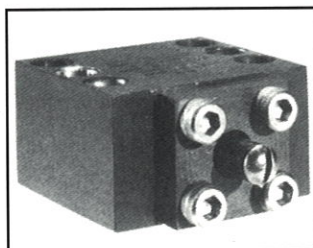

MARVEL "PDE" SWITCH

Pressure differential electric (PDE) switch is designed to provide an electrical indication of a filter element requiring replacement as it loads with contaminant. The switch is rated at .5 amp at 24 volt D.C., and 1 amp at 12 volt D.C. Operation is a grounding circuit requiring only one electrical lead for a single installation. It is a normally open switch.

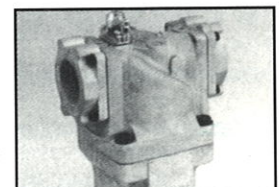

MARVEL TB® FILTER WITH OPTIONAL COLORGAGE® INDICATOR

FLUID TABLE

Group A	Group B*	Group C
Hydraulic Oils	High Water Base Fluids	Phosphate Ester Base Fluids
Lubricants	Water Glycols	
Coolants		
Printing Inks	*All Group B applications are recommended to use either synthetic (8203) or cleanable media.	

TABLE II PORT ADAPTERS (PORT ADAPTERS SHIPPED UNMOUNTED)

Port Adapter code	NPTF Pipe	SAE Straight Thread	SAE 4-Bolt	Service Part Number For Replacement SEE NOTE 1
000				Without Port Adapters
121	3/4-14*			265121-16K
122		1 1/16-12*		265122-22K
124			.75*	265124-16K
161	1-11 1/2			265161-16K
162		1 5/16-12		265162-16K
164			1.00	265164-16K
201	1 1/4-11 1/2			265201-16K
202		1 5/8-12		265202-16K
204			1.25	265204-16K
241	1 1/2-11 1/2			265241-16K
242		1 7/8-12		265242-16K
244			1.50	265244-16K
321	2-11 1/2			265321-16K
322		2 1/2-12		265322-16K
324			2.00	265324-16K

*Consult factory for dimensional changes. NOTE: MIXED PORTING AVAILABLE-CONSULT FACTORY.
 NOTE 1: Service part includes 2 port adapters with 2 seals and 8 bolts
 NOTE 2: Welded tube steel port adapter available

TABLE I HOUSING ASSEMBLY NUMBER PREFIX

Length	Group A Fluids	Group B Fluids	Group C Fluids*
Standard	265	265	266
Extended	267	267	268
Double	269	269	270

*Group C Fluids require fluorocarbon seals

MARVELINE TB FILTER WEIGHTS

	265000	267000	269000
Disposable Elements	10.2lbs.	10.7lbs.	13.5lbs.
Cleanable Elements	10.3lbs.	10.8lbs.	13.7lbs.

ADD 2.25 LBS FOR PORT ADAPTER SET

MARVEL 8200 SERIES SYNTHETIC MEDIA

- HIGH FILTRATION EFFICIENCY
- GREATER DIRT-HOLDING CAPACITY
- HIGHER FLO-RATE CAPACITY

TYPICAL TEST RESULTS

	β5	β10	β20
Beta Ratio	8	50	>1000
Efficiency	87.5%	98.0%	99.9+%

TABLE III HEAD AND HOUSING OPTIONS

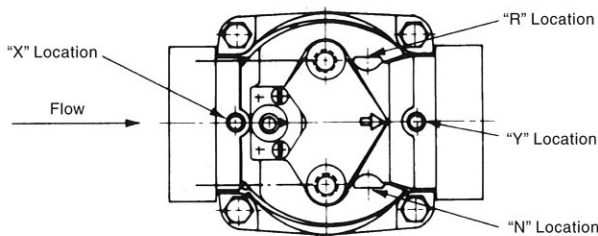

Code	Description
-	No Options (Insert Dash)
C	Head Machined for Indicator
N	Outlet Gage Port (Right Side)
R	Outlet Gage Port (Left Side)
X	Inlet Gage Port (Top)
Y	Outlet Gage Port (Top)
T	Reversed Housing Bolts (Consult Factory)

NOTE: If no housing options are selected—insert dash in housing assembly number.

TABLE IV BY-PASS VALVE OPTION

Bypass Code	Bypass Valve Setting*
0000	Without By-Pass
0300	3 PSID (.21 Bars)
0500	5 PSID (.34 Bars)
0800	8 PSID (.55 Bars)
1000	10 PSID (.68 Bars)
1500	15 PSID (1.03 Bars)
2000	20 PSID (1.37 Bars)
2500	25 PSID (1.72 Bars)
4000	40 PSID (2.75 Bars)
5000	50 PSID (3.44 Bars)

*BY-PASS VALVE "CRACKS" OPEN AT SETTING ±10%
 SEE GRAPH 1 FOR BY-PASS VALVE DATA

TABLE V ELEMENT LENGTH PREFIX NUMBER

Length	Group A Fluids	Group B Fluids*	Group C Fluids
Standard	576366	576366G	577366
Extended	578366	578366G	579366
Double	5 & 676366	5 & 676366G	5 & 677366

*Recommended synthetic (8203) or cleanable media

TABLE VI ELEMENT OPTIONS

Letter	Description
-	No options insert dash in position VI
M	Marvel Magrods (Includes Pleating)
MN	Element Pleated for Magrods (No magrods supplied)
G	For Group B Applications (Furnish fluid specifications)

TABLE VII MEDIA SUFFIX NUMBERS¹

DISPOSABLE MEDIA					CLEANABLE MEDIA ³		
Nominal Micron Rating	Media Only Suffix Number	Media With Inside Mesh Back-Up ²	Media With Outside Mesh Back-Up	Media With Both Inside and Outside Mesh Back-Up ²	Micron Rating	Suffix Number	Description
0.6	7101	7201	7301	7401	914	1202	20 Mesh
3	7103	7203	7303	7403	546	1203	30 Mesh
3	-	8203	-	8403	385	1204	40 Mesh
10	7110	7210	7310	7410	308	1205	50 Mesh
20	7120	7220	7320	7420	262	1206	60 Mesh
20	-	8220	-	8420	180	1208	80 Mesh
100	7199	7299	7399	7499	141	1210	100 Mesh
					105	1215	150 Mesh
					74	1220	200 Mesh
					2 Nominal	2210 ³	8-10 S.S. Micron
					5 Nominal	2215 ³	15-16 S.S. Micron
					10 Nominal	2225 ³	19-21 S.S. Micron
					17 Nominal	2240 ³	36-40 S.S. Micron

NOTE 1. FILTER ELEMENTS 576366-7110, 676366-7110, AND 578366-7110 HAVE BEEN QUALIFIED PER MIL-F52723 (MF) CONSULT FACTORY FOR DETAILS.

NOTE 2. MESH REINFORCEMENT IS RECOMMENDED FOR SHOCK RETURN LINES. FOR INSTALLATIONS WITH HIGH BY-PASS FLOW. OR FOR MOMENTARY REVERSE FLOW APPLICATIONS. CONSULT FACTORY FOR RECOMMENDATIONS.

Note 3. MAY REQUIRE ULTRASONIC CLEANERS. CONSULT FACTORY

DRAWING 2 PARTS I.D.

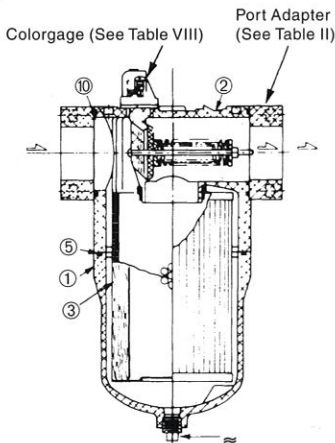

Item	Part Name	Part Number
1	Housing	Standard Length 265000-1 Extended Length 267000-1 Double Length 269000-1
2	Head Assembly	265000-xxxx-2 By-Pass Valve Code from Table IV Head Assembly Shipped without Port Adapters
3	Filter Element(s)	See Tables V, VI, VII
4	Head Washers	255000-8A (Not Illustrated) Quantity of Four per Filter
5	Housing Seal	265000-3 for Group A & B Fluids 266000-3 for Group C Fluids
6	Drain Plug	25000-4
7	Head Bolts	255000-8 (Not Illustrated) Quantity of Four per Filter
8	Twin Sleeve	259000-17 (Not Illustrated) Used with Double Length Housing
9	Port Adapter Screws	851320-23 (Not Illustrated) Quantity of Four per Adapter
10	Port Adapter Seal	265000-15 for Group A & B Fluids 266000-15 for Group C Fluids

Table VIII OPTIONAL INDICATOR PART NUMBERS¹

Setting ²	Colorgage® 3,4 Visual Indicator	PDE Electric ^{3,4} Indicator Switch
2 PSID (.14 Bar)	909420-02	MEC 404-0200
3 PSID (.20 Bar)	909420-03	MEC 404-0300
5 PSID (.34 Bar)	909420-05	MEC 404-0500
8 PSID (.55 Bar)	909420-08	MEC 404-0800
10 PSID (.68 Bar)	909420-10	MEC 404-1000
12 PSID (.83 Bar)	909420-12	MEC 404-1200
15 PSID (1.03 Bar)	909420-15	MEC 404-1500
20 PSID (1.38 Bar)	909420-20	MEC 404-2000
25 PSID (1.72 Bar)	909420-25	MEC 404-2500
40 PSID (2.76 Bar)	909420-40	MEC 404-4000

NOTE 1: INDICATOR SETTING SHOULD BE ONE SETTING LOWER THAN BY-PASS VALVE SETTING. EXAMPLE: USE A 20 PSID COLORGAGE WITH A 25 PSID BY-PASS VALVE.

NOTE 2: COLORGAGE® AND PDE SWITCH SETTING ARE ± 10%

NOTE 3: PETROLEUM BASE FLUIDS ONLY. CONSULT FACTORY USE WITH OTHER FLUIDS.

NOTE 4: IN ADDITION TO SPECIFYING OPTIONAL INDICATOR ALSO ADD LETTER "C" TO HOUSING ASSEMBLY NUMBER.

RECOMMENDED BOLTS TORQUES FOR SERVICE

Housing Bolts: 50 ft-lbs Dry or 35 ft-lbs Lubricated (Nominal Torque)

Port Adapter Bolts: 15 ft-lbs Dry or 10 ft-lbs Lubricated (Nominal Torque)

Graph 1. Bypass Valve Data
 Curve 1. Flow Thru 25 PSI By-Pass Cracking
 Curve 2. Flow Thru 15 PSI By-Pass Cracking

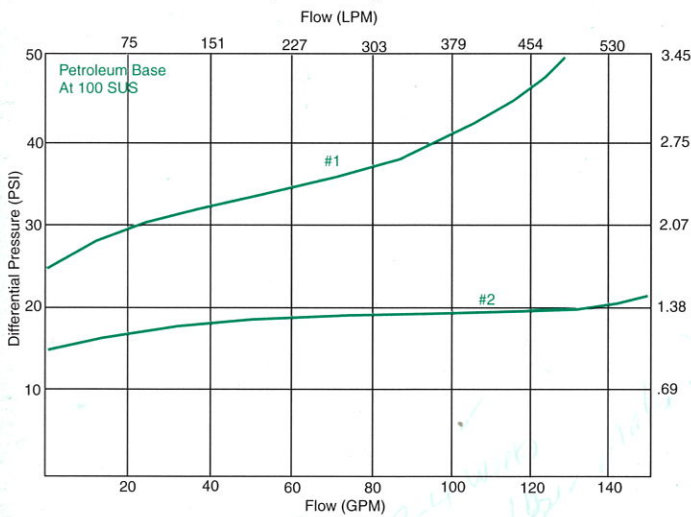

Graph 2. Typical Pressure Drop Versus Flow: Standard Length Assembly
 265321-0000/576366-Media Part Number (See Below)

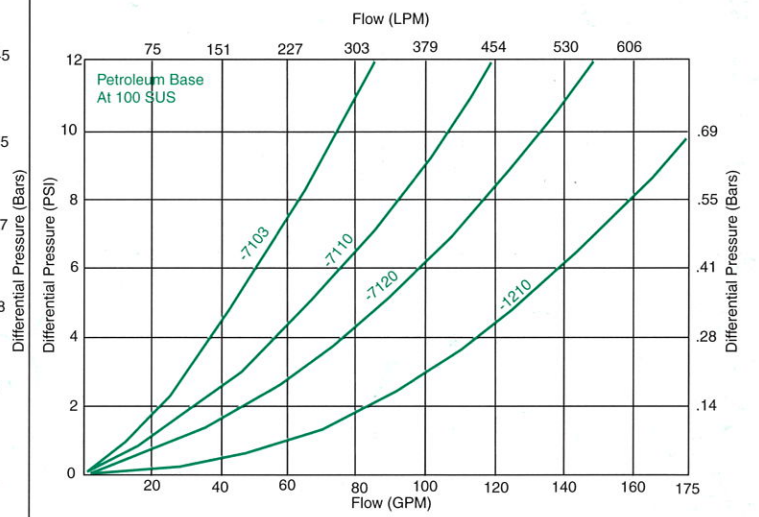

Graph 3. Typical Pressure Drop Versus Flow: Extended Length Assembly
 267321-0000/578366-Media Part Number (See Below)

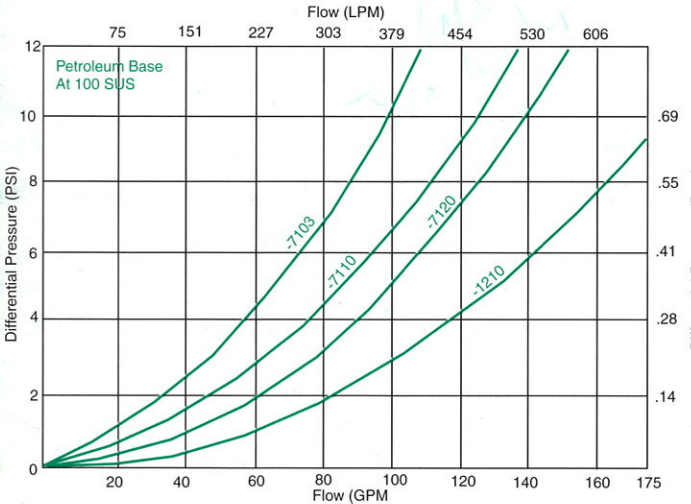

Graph 4. Typical Pressure Drop Versus Flow: Double Length Assembly
 269321-0000/5 & 67366-Media Part Number (See Below)

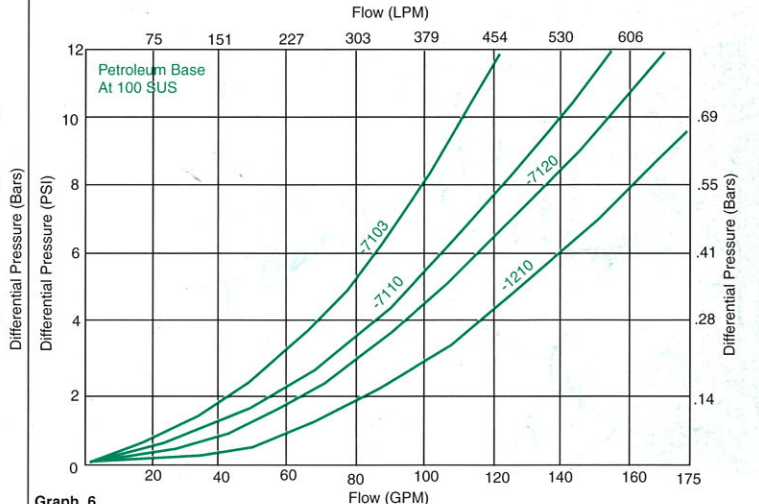

Graph 5. Typical Pressure Drop Versus Flow:
 8203 Synthetic Media
 Curve 1. 265321-0000/576366-8203
 Curve 2. 267321-0000/578366-8203
 Curve 3. 269321-0000/5 & 67366-8203

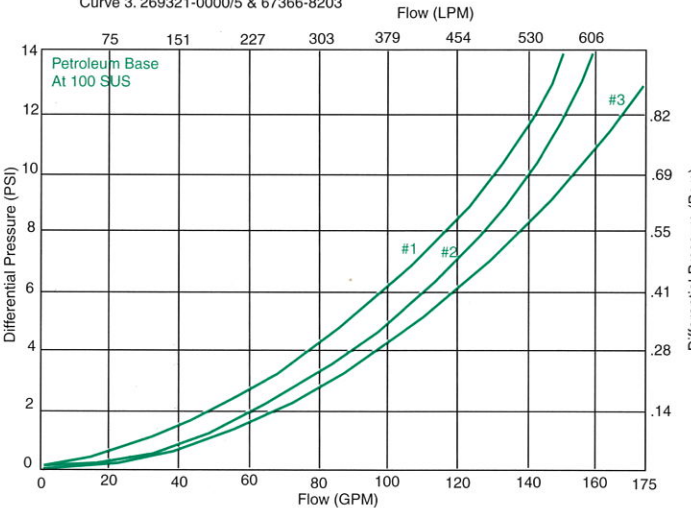

Graph 6. Effect of Viscosity on 10 Micron Media
 Curve 1. 265321-0000/576366-7110 at 225 SUS
 Curve 2. 265321-0000/576366-7110 at 600 SUS
 Curve 3. 267321-0000/578366-7110 at 225 SUS
 Curve 4. 267321-0000/578366-7110 at 600 SUS
 Curve 5. 269321-0000/5 & 67366-7110 at 225 SUS
 Curve 6. 269321-0000/5 & 67366-7110 at 600 SUS

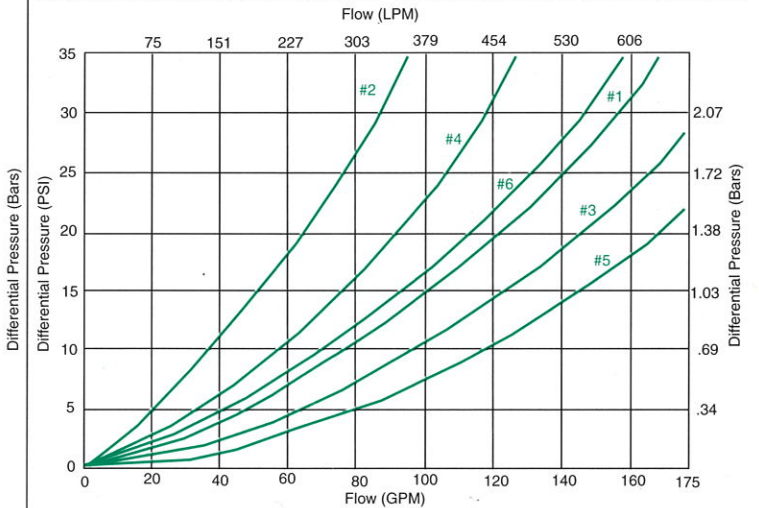

350 PSIG MAXIMUM OPERATING PRESSURE

"TB" SERIES DIMENSIONS

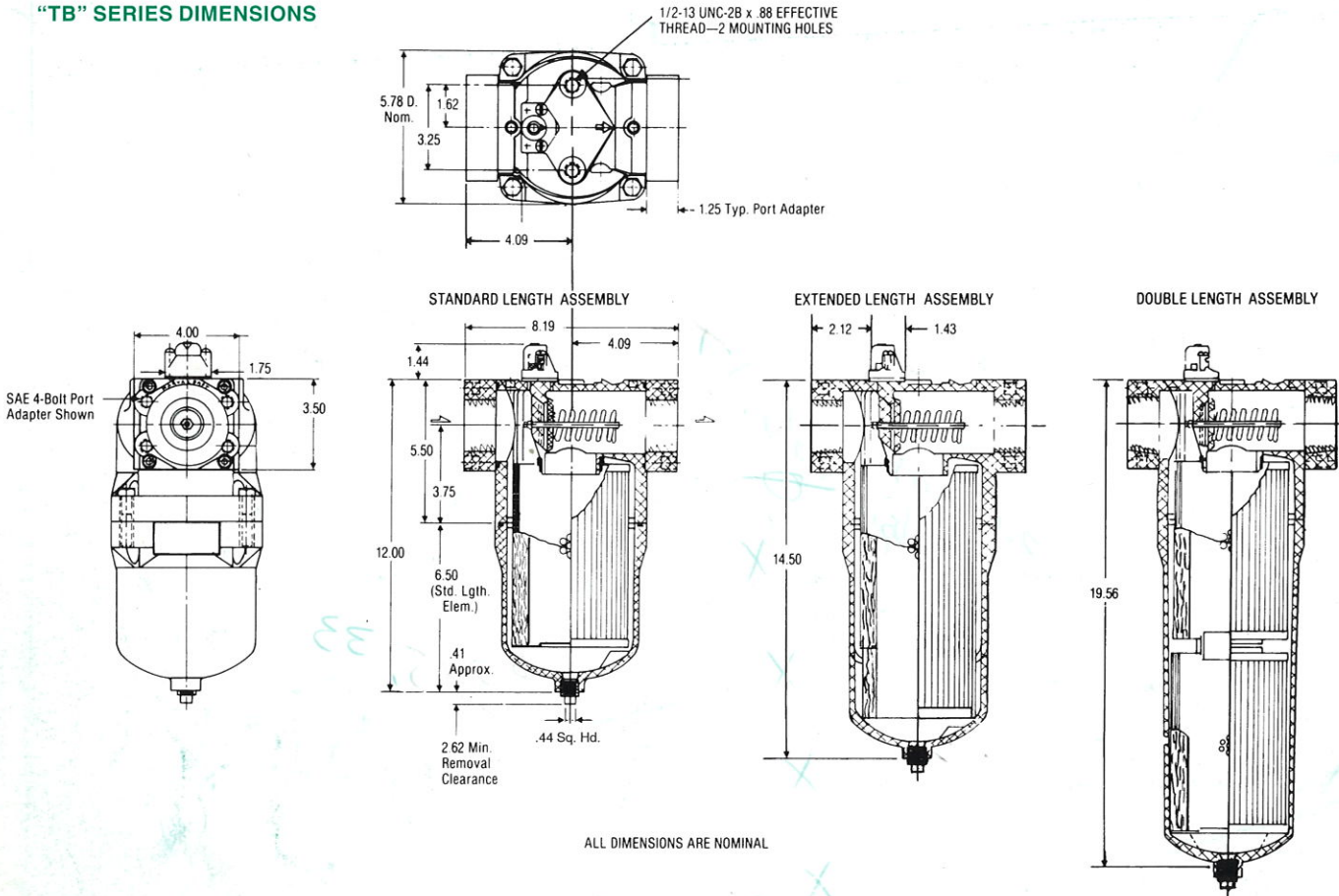

Graph 7. Effect of Temperature: Burst Rating and Operating Pressure Rating. Maximum Operating Temperature 300°F (148.9°C) Maximum

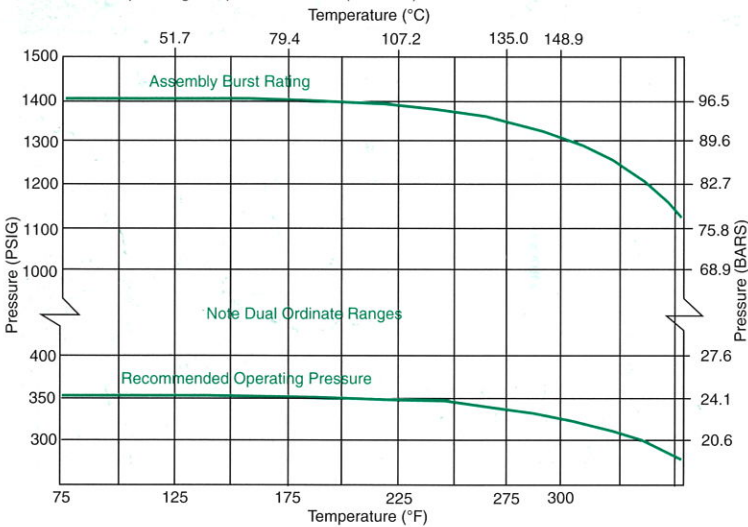

SPECIAL REQUIREMENTS?

WE CAN SAVE YOU TIME AND MONEY!

SPECIAL ELBOW PORTING AVAILABLE WITH MARVEL TB DESIGN

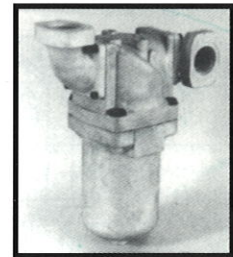

MARVEL ENGINEERING COMPANY

2085 N. HAWTHORNE AVE. • MELROSE PARK, IL 60160-1173
 PHONE (708) 343-4090 FAX (708) 343-4159
 E-MAIL marvelfilters@aol.com www.marvelengineering.com

MARVELINE TB, SERIES FILTERS ARE PROTECTED BY ONE OR MORE PATENTS AND HAVE PATENTS APPLIED FOR.

*© REGISTERED TRADEMARK MARVEL ENGINEERING COMPANY



NFPA

Solutions through motion technology

MEMBER