

1/2"-14
NPTF

3/4"-14
NPTF

1"-11 1/2
NPTF

3/4"-16
SAE
Straight

1 1/16"-12
SAE
Straight

1 5/16"-12
SAE Straight

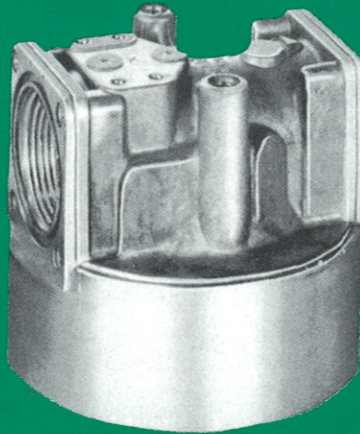

1 1/4"-11 1/2 NPTF
Integral in Head



Standard length housing
331000 Series



Extended length housing
333000 Series



Double length housing
335000 Series

MARVELINE TT-II SERIES FEATURES

- Rugged Die Cast Aluminum Construction
- Optional Visual or Electrical Indicators
- Large Flow Area Integral By-Pass Valve
- Positive Radial Filter Element Seal
- Custom Designed Port Adapters are Available to meet any need
- Mix and Match Port Sizes and Styles to fit YOUR needs
- With or Without By-Pass Valve
- Optional 1/8-27 NPTF Gage Ports
- Requires Only 2 5/8" Clearance for Element Service
- Optional Marvelmag® magnetic filtration
- Wide Selection Of Filter Media

3000 PSIG (206 Bars) Minimum Burst @ 68°F (20°C)
 Cleanable Media Elements from 20 Mesh to 10 Micrometres (Microns)
 Disposable Media Elements from 100 Micrometres to 0.6 Micrometres (Microns)

300°F (150°C) Maximum Operating Temperature
 "T" Type Filters with Threaded Housings and Bolt-On-Port Adapters
 750 PSIG (51.7 Bars) Maximum Operating Pressure
 Flows to 75 GPM (300 l/Min)

Marveline TT-II® 750 PSIG Series Filters

331000 Series

How to Order Marveline TT-II® Filters

1. Insure Operating Pressure does not exceed 750 PSIG (51.7 Bars).
2. Examine pressure drop versus flow curves, (page 5). For desired media select standard, extended or double length filter element.
3. Examine Fluid Table, and determine fluid group. Group, A, B, or C.
4. Select housing length from Table I to match selected element length. Insert this number into part number position I.
5. Select port size and style number from Table II and insert into part number position II.
6. Select housing option(s) letter from Table III and insert into part number position III.
7. Select by-pass valve option number from Table IV and insert into part number position IV.
8. Select element length prefix number from Table V and insert into part number position V.
9. Select element option(s) letter from Table VI and insert into part number position VI.
10. Select element media suffix number from Table VII and insert into part number position VII.
11. Select optional visual or electric indicator part number from Table VIII and insert into part number position VIII.

Example

Housing Assembly Number				Element Number			Optional Indicator Number
333	162	C	2500	560206	M	7110	MEC-404-2000
Position I	Position II	Position III	Position IV	Position V	Position VI	Position VII	Position VIII

NOTE: POSITION I NUMBER FROM TABLE I, POSITION II NUMBER FROM TABLE II, ETC.
 ABOVE EXAMPLE: 333162 C 2500/560206 M 7110/MEC-404-2000

Marveline TT-II Accessories

See Tables VI and VII for Ordering



MARVEL "PDC" COLORGAGE® INDICATOR

Filter element condition indicator combines reliable "pressure-differential" operating principle with attention-compelling color Bands (Green, Yellow, Red—as unmistakable as traffic lights) to clearly pre-warn of element clogging. Available integrally mounted on filter head or subplate mounted for remote or panel usage, (as illustrated at left).

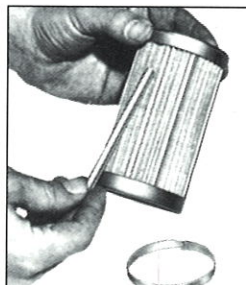

MARVELMAG® MAGNETIC FILTER SHIELD

So easy to service! "Lay-in...Lift-out" Magnetic rods. MarvelMag Shield is formed by individual magnetic rods placed in grooves on outer surface of Synclinal element. To clean rods, just lift out, wipe off, and lay them back in grooves. Slip-on spring clip keeps rods from being magnetically dislodged accidentally.

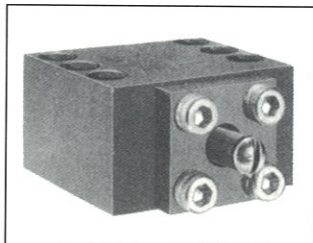

MARVEL "PDE" SWITCH®

Pressure differential electric (PDE) switch is designed to provide an electrical indication of a filter element requiring replacement as it loads with contaminant. The switch is rated at .5 amps at 24 volt D.C., and 1 amp at 12 volt D.C. Operation is a grounding circuit requiring only one electrical lead for a simple installation. It is a normally open switch.

FLUID TABLE

Group A	Group B	Group C
Hydraulic Oils	High Water	Phosphate
Coolants	Base Fluids	Ester
Lubricants		Base
Water Glycols		

TABLE II PORT ADAPTERS

Housing Port Part Number	NPTF Pipe	SAE Straight Thread	Service Part ² Number for replacement
081	1/2"-14		331081-22K
082		3/4"-16	331082-22K
121	3/4"-14		331121-22K
122		1 1/16"-12	331122-22K
161	1"-11 1/2		331161-22K
162		1 5/16"-12	331162-22K
201	1 1/4"-11 1/2		(Integral)

1. Port Adapters shipped unmounted
2. Includes screws and seals

MARVELINE TT-II 750 PSIG FILTER ASSEMBLY WEIGHTS

	331000	333000	335000
Disposable Elements	4 lb. 3 oz.	5 lb. 3 oz.	6 lb. 11 oz.
Cleanable Elements	4 lb. 4 oz.	5 lb. 4 oz.	6 lb. 12 oz.

ADD 7 OZ. FOR PORT ADAPTERS

TABLE I HOUSING ASSEMBLY NUMBER PREFIX

Length	Group A Fluids	Group B Fluids	Group C Fluids
Standard	331	331	332
Extended	333	333	334
Double	335	335	336

*Anodization may be required. Consult factory for recommendation.

TABLE IV BY-PASS VALVE OPTION

Housing Suffix Number	By-Pass Valve Setting*
0000	No By-Pass
0300	3 PSID (.20 Bars)
0500	5 PSID (.34 Bars)
0800	8 PSID (.54 Bars)
1000	10 PSID (.68 Bars)
1200	12 PSID (.82 Bars)
1500	15 PSID (1.02 Bars)
2000	20 PSID (1.36 Bars)
2500	25 PSID (1.70 Bars)
4000	40 PSID (2.72 Bars)
5000	50 PSID (3.40 Bars)

* BY-PASS VALVE "CRACKS" OPEN AT SETTING ± 10%

TABLE III HEAD AND HOUSING OPTIONS See Note Below

Gage Port Options 1/8" NPTF Threads	Insert Letter in Position III	Description
J-LOCATION	J	Inlet
K-LOCATION	K	Outlet
Y-LOCATION	L	Outlet
X-LOCATION	M	Inlet
	X	Inlet
	Y	Outlet
	U*	Anodized Head
	C	Machined For Indicator
	-	No Options
	-	Insert Dash

NOTE: If no options selected insert dash in part number position III.

*Recommended for high water base fluids and for water.

DRAWING 1. DIMENSIONS INCHES (MM)

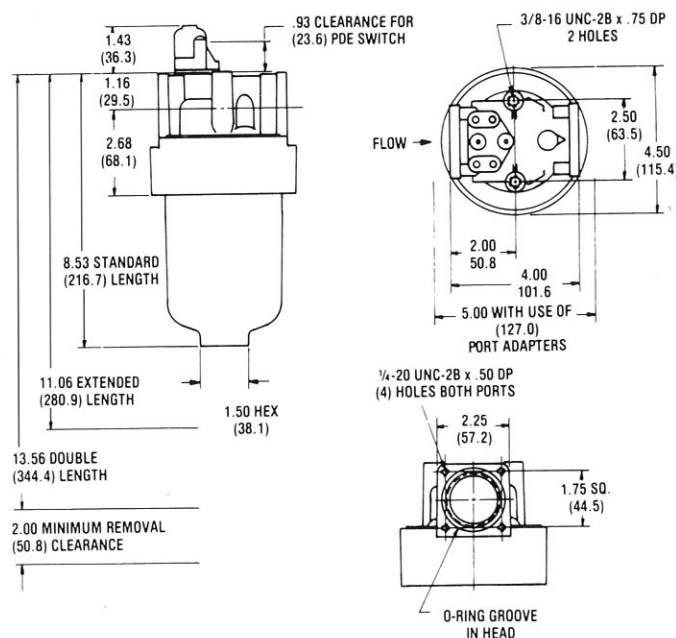

TABLE V ELEMENT LENGTH PREFIX NUMBER

Length	Group A Fluids	Group B Fluids	Group C Fluids
Standard	529206	529206 G	530206
Extended	560206	560206 G	561206
Double	562206	562206 G	563206

TABLE VI ELEMENT OPTIONS

Letter	Description
M	Marvel Magrods (Includes Pleating)
M N	Element Pleated for Magrods (No magrods supplied)
R	O-Ring Seal in lieu of square seal
-	No options

TABLE VII MEDIA SUFFIX NUMBERS 1 2

Paper (Disposable) Media

Paper Only		Paper With Inside Mesh Back-Up ²		Paper With Outside Mesh Back-Up ²		Paper With Both Inside & Outside Mesh Back-Up ²	
Suffix Number	Micronic Rating	Suffix Number	Micronic Rating	Suffix Number	Micronic Rating	Suffix Number	Micronic Rating
7101	0.6 Nom.	7201	0.6 Nom.	7301	0.6 Nom.	7401	0.6 Nom.
7103	3 Nom.	7203	3 Nom.	7303	3 Nom.	7403	3 Nom.
7110	10 Nom.	7210	10 Nom.	7310	10 Nom.	7410	10 Nom.
7120	20 Nom.	7220	20 Nom.	7320	20 Nom.	7420	20 Nom.
7199	100 Nom.	7299	100 Nom.	7399	100 Nom.	7499	100 Nom.

Cleanable Media

Mesh and Metal Cloth ³		
Suffix Number	Description	Micronic Rating
1202	20 Mesh	914
1203	30 Mesh	546
1204	40 Mesh	385
1205	50 Mesh	308
1206	60 Mesh	262
1208	80 Mesh	180
1210	100 Mesh	141
1215	150 Mesh	105
1220	200 Mesh	74
2210 ³	8-10 S.S.	10
2215 ³	10-15 S.S.	15
2225 ³	25 S.S.	25
2240 ³	40 S.S.	40

NOTE 1. FILTER ELEMENTS 529206-7110, 560206-7110, AND 562206-7110 HAVE BEEN QUALIFIED PER MIL-F-52723(ME). CONSULT FACTORY FOR DETAILS.

NOTE 2. MESH REINFORCEMENT IS RECOMMENDED FOR SHOCK RETURN LINES. FOR INSTALLATIONS WITH HIGH BY-PASS FLOW, OR FOR MOMENTARY REVERSE FLOW APPLICATIONS, CONSULT FACTORY FOR RECOMMENDATIONS.

NOTE 3. MAY REQUIRE SPECIAL SONIC CLEANERS. CONSULT FACTORY.

NOTE 4. ALSO AVAILABLE IN FIBERGLASS AND OTHER MEDIAS..

DRAWING 2. PARTS IDENTIFICATION

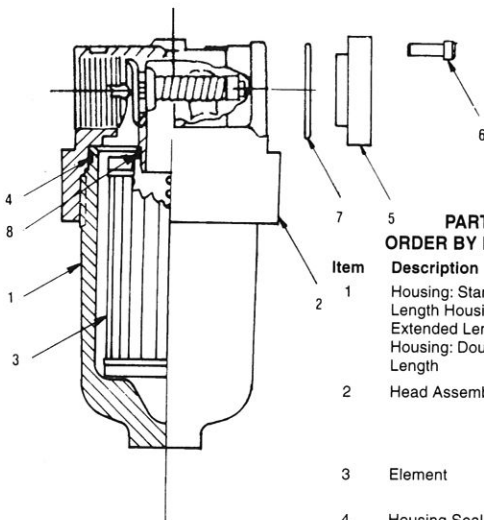

PARTS LIST:

Item	Description	Part No.
1	Housing: Standard	311000-1
1	Length Housing: Extended Length	313000-1
1	Housing: Double Length	315000-1
2	Head Assembly	331201- (By-Pass Valve Suffix from Table IV)-2
3	Element	See Tables V, VI, VII
4	Housing Seal	301000-3
5	Port Adapter	See Table II
6	Adapter Screws	331160-23
7	Adapter Seal	296000-14
8	Element Seal	529206-7

TABLE VIII OPTIONAL INDICATOR PART NUMBERS¹

Setting ²	Colorgage 2, 3, 4 Visual Indicator	PDE ELECTRIC 2, 4 Switch
2 PSID (.14 Bar)	909420-02	MEC 404-0200
3 PSID (.20 Bar)	909420-03	MEC 404-0300
5 PSID (.34 Bar)	909420-05	MEC 404-0500
8 PSID (.54 Bar)	909420-08	MEC 404-0800
10 PSID (.68 Bar)	909420-10	MEC 404-1000
15 PSID (1.02 Bar)	909420-15	MEC 404-1500
20 PSID (1.36 Bar)	909420-20	MEC 404-2000
25 PSID (1.70 Bar)	909420-25	MEC 404-2500
40 PSID (2.72 Bar)		MEC 404-4000

1. INDICATOR SETTING SHOULD BE ONE SETTING LOWER THAN BY-PASS VALVE SETTING. EXAMPLE, USE A 20 PSID COLORGAGE WITH A 25 PSID BY-PASS VALVE.

2. BY-PASS VALVE COLORGAGE, AND PDE SWITCH SETTINGS ARE ±10%. BY-PASS "CRACKS" AT SETTING ±10%.

3. PETROLEUM BASE FLUIDS ONLY. CONSULT FACTORY FOR OTHERS.

4. ADD LETTER "C" TO HOUSING OPTION, PART NUMBER POSITION III.

All Graphs: Petroleum Base Hydraulic Fluid
 For pressure drop data for units having 25—50 PSID by-pass valves
 add Curve 4 of Graph 1 to pressure drop Curves in Graphs 2—6.

Graph 1. By-Pass Valve Data Note: Dual Scale Ordinate
 Curve 1. Flow Thru 25 PSID Crack By-Pass At 600 SUS
 Curve 2. Flow Thru 25 PSID Crack By-Pass At 225 SUS
 Curve 3. Flow Thru 25 PSID Crack By-Pass At 100 SUS
 Curve 4. Additional Pressure Drop Due To 25 or 50 PSID By-Pass Valve
 (Add Additional Pressure Drop to No By-Pass Assembly Pressure Differential)

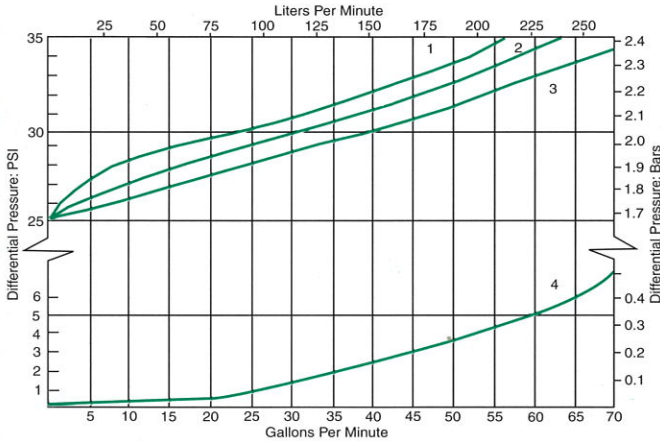

Graph 2. Pressure Drop Verses Flow: Standard Length Assembly
 331201-0000/529206-Below Standard Length Element
 100 SUS

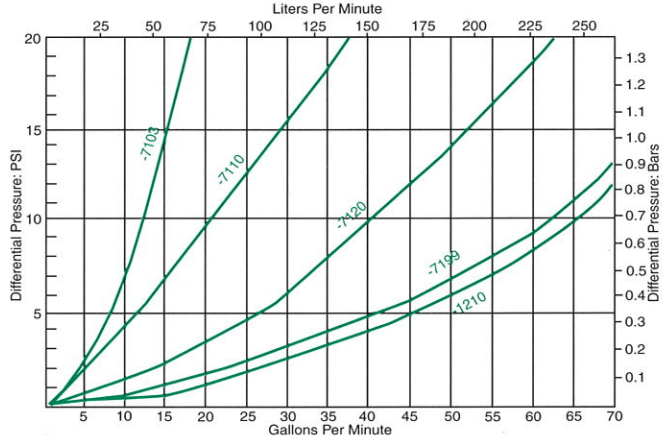

Graph 3. Effect of Viscosity on 5110 Media
 Curve 1. 331201-0000/529206-7110 At 225 SUS Curve 2. 331201-0000/529206-7110 At 600 SUS
 Curve 3. 333201-0000/560206-7110 At 225 SUS Curve 4. 333201-0000/560206-7110 At 600 SUS
 Curve 5. 335201-0000/562206-7110 At 225 SUS Curve 6. 335201-0000/562206-7110 At 600 SUS

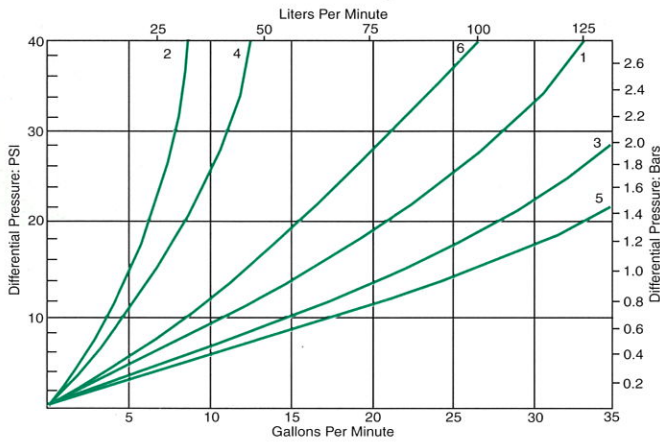

Graph 4. Pressure Drop Verses Flow: Extended Length Assembly
 333201-0000/560206-Below Extended Length Element
 100 SUS

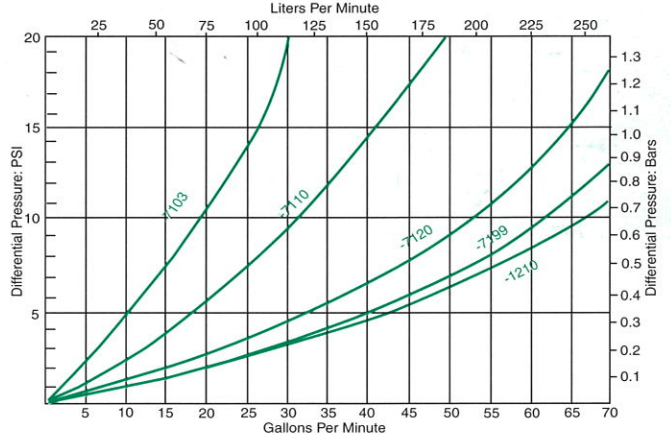

Graph 5. Pressure Drop Verses Flow: 7101 Media 100 SUS
 Curve 1. 331201-0000/529206-7101
 Curve 2. 333201-0000/560206-7101
 Curve 3. 335201-0000/562206-7101

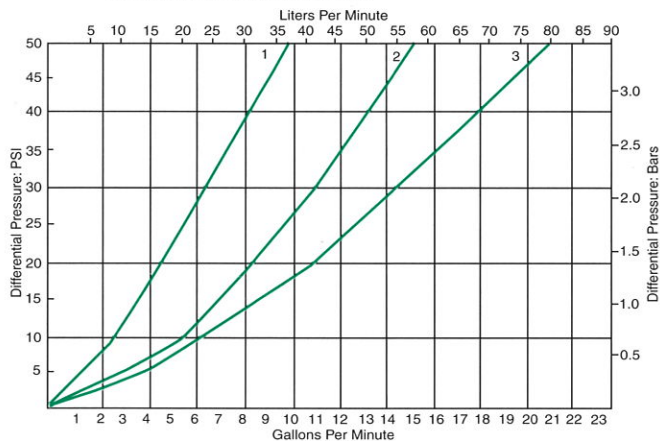

Graph 6. Pressure Drop Verses Flow: Double Length Assembly
 335201-0000/562206-Below Double Length Element
 100 SUS

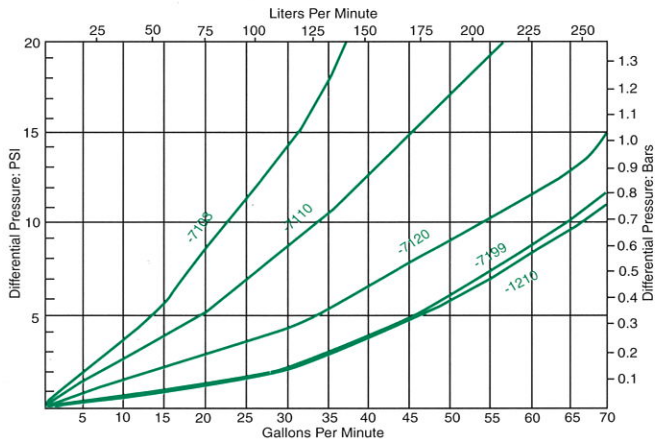

OTHER MARVEL FILTERS

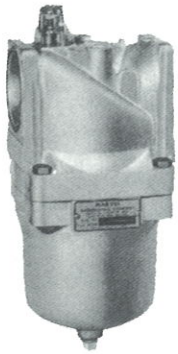

**UP TO 350 PSI—UP TO 150 GPM
NEW MARVELINE TB® WITH 12
INTERCHANGEABLE PORT OPTIONS
AND 3 FILTER-SIZE OPTIONS**

New concept of interchangeable filter ports! 4 pipe thread port adapter sizes—plus 4 straight thread port adapter sizes—plus 4 flange type port adapter sizes. Plus 3 filter-length options: (1) with standard length element; (2) with extended length element; (3) with double length element. A total of 36 options—with all port adapters quickly interchangeable on all 3 filter sizes. Available with Colorgage indicators and Marvelmag Magnets.

See Bulletin TBA

**LINE TYPE
UP TO 150 GPM
MARVELBO-S®**

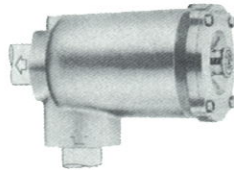

Most popular, dependable, suction filter with famous Colorator Indicator (see below). 2-stage filtration plus MarvelMag. Lightweight, sturdy. Lowest pressure drop. MarvelMag optional.

See Bulletin C-103

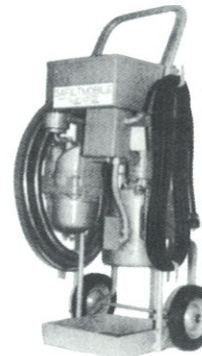

SAFILMOBILE®
Unique new filter cart.

Wheel it anywhere, anytime—inside, outside—to filter/ transfer oil, other liquids at up to 10 GPM.

Safe—all air-powered operates from any air line. Also Available as Electric Powered Unit. (Picture Shown).

Triple Filtration action. Absolutely fail-safe operation.

See Bulletin L-8806

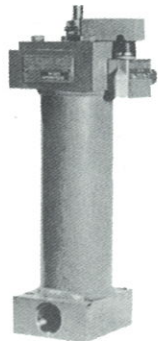

**UP TO 3000 PSI
UP TO 150 GPM**

Extra sturdy, dependable, large capacity "R2" and "R5" models with famous Colorator Indicators and (optional) Marvelmag Magnets. Single and double element models standard. 3 & 4 element models also available.

See Bulletin C-103



**MARVEL
MHP®
6000 PSI (Max)
Pressure Filter.**

$\frac{3}{4}$ " to $1\frac{5}{8}$ " straight thread ports. Filtration to 10 micrometers.

See Form L-8808



**MARVELBO-SC FILTER
Continuous Flow In-Tank
Suction Filter.**

The Marvel SC filter is designed to permit filter element servicing without machine shutdown. The model SC saves space by mounting inside the reservoir, it is self-priming and is designed for low pressure drop. The model SC is available with either disposable or cleanable elements and has a standard feature, a visual element condition indicator. Magnetic filtration is optional.

See Form L-1172-2

Graph 7. Effect of temperature Burst Rating and Operating Pressure Rating
Note: Dual Ordinate Ranges; Maximum Operating Temperature 300°F (150°C)

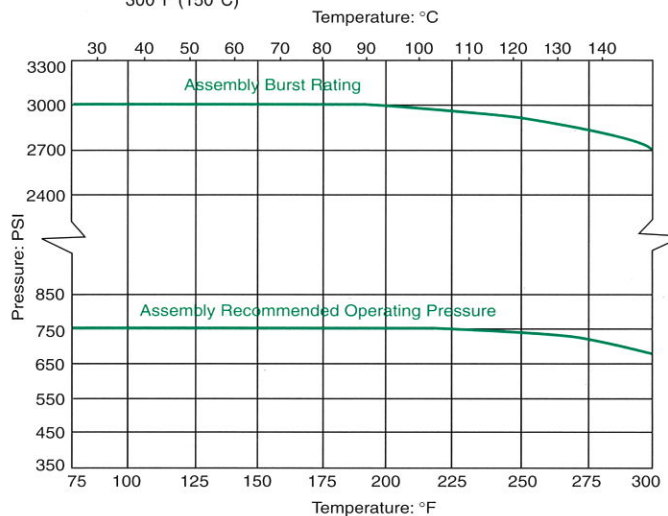

MARVEL ENGINEERING COMPANY

2085 N. HAWTHORNE AVE. • MELROSE PARK, IL 60160-1173
 PHONE (708) 343-4090 FAX (708) 343-4159
 E-MAIL marvelfilters@aol.com www.marvelengineering.com