

1/2"-14
NPTF

3/4"-14
NPTF

1"-11 1/2
NPTF

1 1/4"-11 1/2 NPTF
Integral in Head

3/4"-16
SAE
Straight

1 1/16"-12
SAE
Straight

1 5/16"-12
SAE Straight



STANDARD LENGTH CARTRIDGE
455000 SERIES



EXTENDED LENGTH CARTRIDGE
457000 SERIES

MARVELINE TT-II® SPIN-ON FEATURES

- Rugged Die Cast Aluminum Head
- Optional Visual or Electrical Indicators
- Large Flow Area Integral By-Pass Valve
- Custom Designed Port Adapters are Available to meet any need
- Mix and Match Port Sizes and Styles to fit YOUR needs
- With or Without By-Pass Valve
- Optional 1/8-27 NPTF Gage Ports
- Requires Only 1/16" Clearance For Cartridge Service
- Wide Selection Of Filter Media

240 PSIG (16.5 Bars) Minimum Burst
@ 70°F (20°C)

Disposable Cartridges with 0.6
micrometres to 100 micrometres (microns)
nominal rating.

"T" Type Filters with Threaded
Spin-On Cartridges and
Bolt-on Port Adapters

60 PSIG (4.1 Bars) Maximum Operating
Pressure

Flows to 75 GPM (300 l/min.)

How to Order Marveline TT-II® Spin-on Filters

1. Insure Operating Pressure does not exceed 60 PSIG (4.1 BARS)
2. Examine pressure drop versus flow curves. (Page 4) For desired media select standard or extended length cartridge.
3. Examine fluid table and determine fluid group. Group A, B or C.
4. Select filter head prefix number from table I and insert into position I of part number.
5. Select port size and style number from Table II and insert into part number position II.
6. Select head option(s) letter from Table III and insert into part number position III.
7. Select by-pass valve option number from Table IV and insert into part number position IV.
8. Select cartridge length prefix number from Table V and insert into part number position V.
9. Select cartridge option(s) letter from Table VI and insert into part number position VI.
10. Select cartridge media suffix number from Table VII and insert into part number position VII.
11. Select optional visual or electric indicator part number from Table VIII and insert into part number position VIII.

Example

Housing Assembly Number				Cartridge Number			Optional Indicator Number
296	161	- C -	2500	455217	-	7110	909420-20
Position I	Position II	Position III	Position IV	Position V	Position VI	Position VII	Position VIII

NOTE: POSITION I NUMBER FROM TABLE I, POSITION II NUMBER FROM TABLE II, ETC.
 ABOVE EXAMPLE: 296161-C-2500/455217-7110/909420-20

Marveline TT-II Accessories

See Tables VI and VIII for Ordering

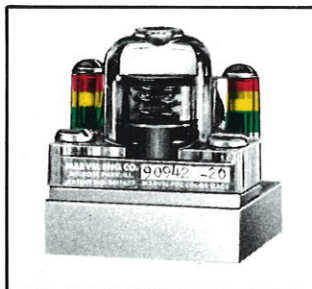

MARVEL "PDC" COLORGAGE® INDICATOR

Filter element condition indicator combines reliable "pressure-differential" operating principle with attention-compelling color Bands (Green, Yellow, Red—as unmistakable as traffic lights) to clearly pre-warn of element clogging. Available integrally mounted on filter head or subplate mounted for remote or panel usage, (as illustrated at left).

FLUID TABLE

Group A	Group B	Group C
Hydraulic Oils	High Water Base Fluids	Phosphate Ester Base Fluids
Coolants	Water Glycols	
Lubricants		

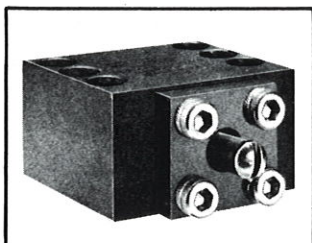

MARVEL "PDE" SWITCH®

Pressure differential electric (PDE) switch is designed to provide an electrical indication of a filter element requiring replacement as it loads with contaminant. The switch is rated at 1 amp at 24 volts D.C., and 2 amps at 12 volts D.C. Operation is a grounding circuit requiring only one electrical lead for a simple installation. It is a normally open switch.

TABLE I FILTER HEAD PREFIX NUMBER

Group A Fluids	Group B Fluids	Group C Fluids
296	296	297

MARVELINE TT-II® SPIN-ON FILTER WEIGHTS

	Group A Fluids	Group B Fluids	Group C Fluids
Standard Length	2 lbs.	4 oz.	
Extended Length	2 lbs.	10 oz.	

Add 5 oz. For Port Adapters

TABLE II PORT ADAPTERS * 1

¹ Port Adapters shipped unmounted
² Includes screws and seals

Housing Port Part Number	NPTF Pipe	SAE Straight Thread	Service Part * 2 Number for replacement
081	½"-14		296081-22K
082		¾"-16	296082-22K
121	¾"-14		296121-22K
122		1 1/16"-12	296122-22K
161	1"-11½		296161-22K
162		1 5/16"-12	296162-22K
201	1 ¼"-11½		(Integral)

TABLE III HEAD AND HOUSING OPTIONS See Note Below

Gage Port Options ½ NPTF Threads	Insert Letter in Position III	Description
	J	Inlet
	K	Outlet
	L	Outlet
	M	Inlet
	X	Inlet
	Y	Outlet
	U*	Andozied Head
	C	Head Machined For Indicator
	—	No Options Insert Dash

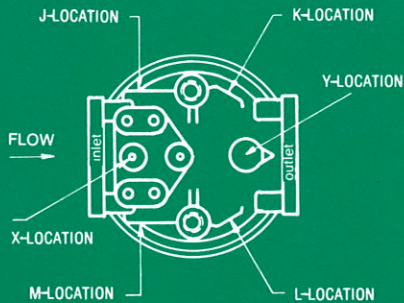

NOTE: If no options selected insert dash in part number position III.

*Recommended for high water base fluids and for water.

TABLE IV BY-PASS VALVE OPTION

Housing Suffix Number	By-Pass Valve Setting *
0000	No By-Pass
0300	3 PSID (.20 Bars)
0500	5 PSID (.34 Bars)
0800	8 PSID (.54 Bars)
1000	10 PSID (.68 Bars)
1200	12 PSID (.82 Bars)
1500	15 PSID (1.02 Bars)
2000	20 PSID (1.36 Bars)
2500	25 PSID (1.70 Bars)
4000	40 PSID (2.72 Bars)
5000	50 PSID (3.40 Bars)

*BY-PASS VALVE "CRACKS" OPEN AT SETTING ± 10%

TABLE V CARTRIDGE LENGTH PREFIX NUMBER

Length	Group A Fluids	Group B Fluids	Group C Fluids
Standard	455217	455217G	456217
Extended	457217	457217G	458217

TABLE VI FILTER CARTRIDGE OPTIONS

Letter	Description
G	Glycols, H.W.B.F.,
—	No option, Insert Dash

Insert Letter In Position VI of Filter Cartridge Part Number

TABLE VII MEDIA SUFFIX 1 NUMBERS

Suffix Number	Micronic Rating	Cartridge Color
7101	0.6 Nominal	Gold
7103	3 Nominal	Yellow
7110	10 Nominal	White
7120	20 Nominal	Red
7199	100 Nominal	Blue
1210	100 Mesh	Gray

NOTE 1: Spin-On Filter Cartridge 455217-7110 has Been Qualified per MIL-F-52723 (ME). Consult Factory For Details.

TABLE VIII OPTIONAL INDICATOR PART NUMBERS¹

Setting ²	Colorgage® ^{3,4} Visual Indicator	PDE Electric ^{3,4} Indicator Switch
2 PSID (.14 Bar)	909420-02	MEC 404-0200
3 PSID (.20 Bar)	909420-03	MEC 404-0300
5 PSID (.34 Bar)	909420-05	MEC 404-0500
8 PSID (.55 Bar)	909420-08	MEC 404-0800
10 PSID (.68 Bar)	909420-10	MEC 404-1000
12 PSID (.83 Bar)	909420-12	MEC 404-1200
15 PSID (1.03 Bar)	909420-15	MEC 404-1500
20 PSID (1.38 Bar)	909420-20	MEC 404-2000
25 PSID (1.72 Bar)	909420-25	MEC 404-2500
40 PSID (2.76 Bar)	909420-40	MEC 404-4000

NOTE 1: INDICATOR SETTING SHOULD BE ONE SETTING LOWER THAN BY-PASS VALVE SETTING. EXAMPLE: USE A 20 PSID COLORGAGE® WITH A 25 PSID BY-PASS VALVE.

NOTE 2: COLORGAGE® AND PDE SWITCH SETTINGS ARE ± 10%.

NOTE 3: PETROLEUM BASE FLUIDS ONLY. CONSULT FACTORY USE WITH OTHER FLUIDS.

NOTE 4: IN ADDITION TO SPECIFYING OPTIONAL INDICATOR IN POSITION VIII, ALSO ADD LETTER "C" TO HOUSING OPTION IN POSITION III.

Marveline TT-II® Spin-on Filters

DRAWING 1. DIMENSIONS

DIMENSIONS: INCHES (mm)

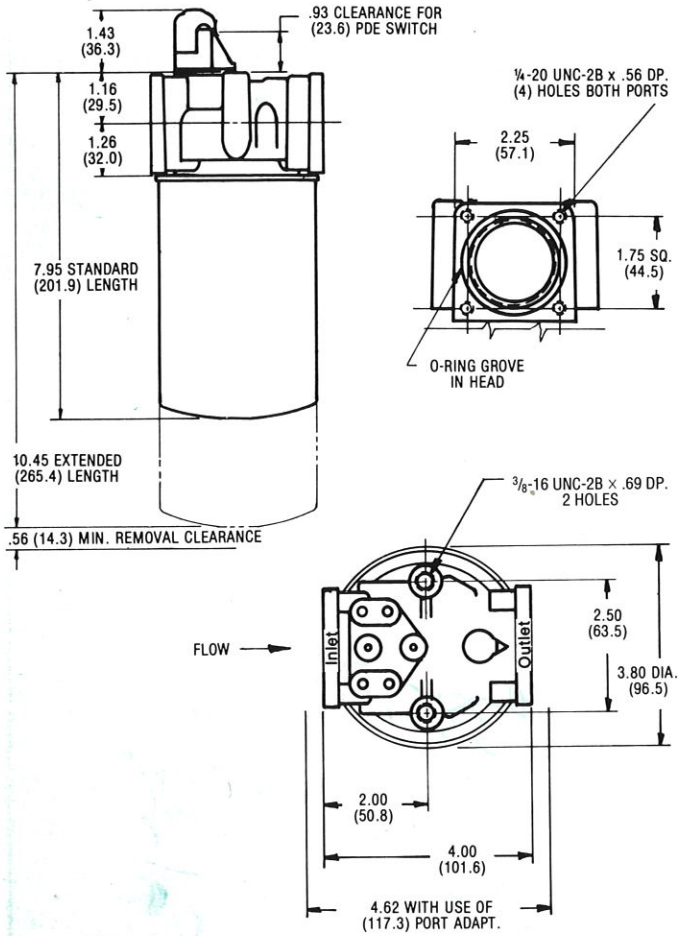

DRAWING 2. PARTS IDENTIFICATION

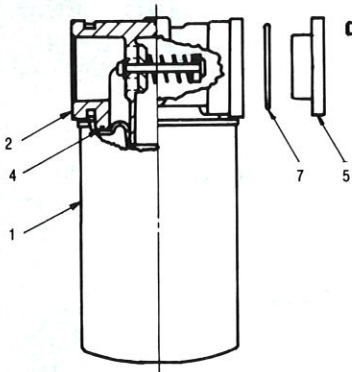

PARTS LIST: ORDER BY PART NUMBER

Item	Description	Part No.
1	Cartridge	See tables V, VI & VII
2	Head Assembly	296000 (by-pass valve suffix number from table IV)
4	Cartridge Seal	Part of Item 1 296000-18
5	Port Adapter	See table II
6	Adapter Screw	296000-23
7	Adapter Seal	296000-14A



MARVEL ENGINEERING COMPANY
 2085 N.HAWTHORNE AVE. • MELROSE PARK, IL 60160-1173
 PHONE (708) 343-4090 FAX (708) 343-4159
 E-MAIL marvelfilters@aol.com www.marvelengineering.com

MARVELINE TT-II SERIES FILTERS ARE PROTECTED BY ONE OR MORE PATENTS AND HAVE PATENTS APPLIED FOR.

®REGISTERED TRADEMARK MARVEL ENGINEERING COMPANY

Bulletin TT-II-296
 Form S010182-E

Graph 1. Pressure Drop Versus Flow
 Standard Length Cartridge
 296201-0000/455217-(Below)

All Graph Data
 Petroleum Base Fluids
 At 100 SUS

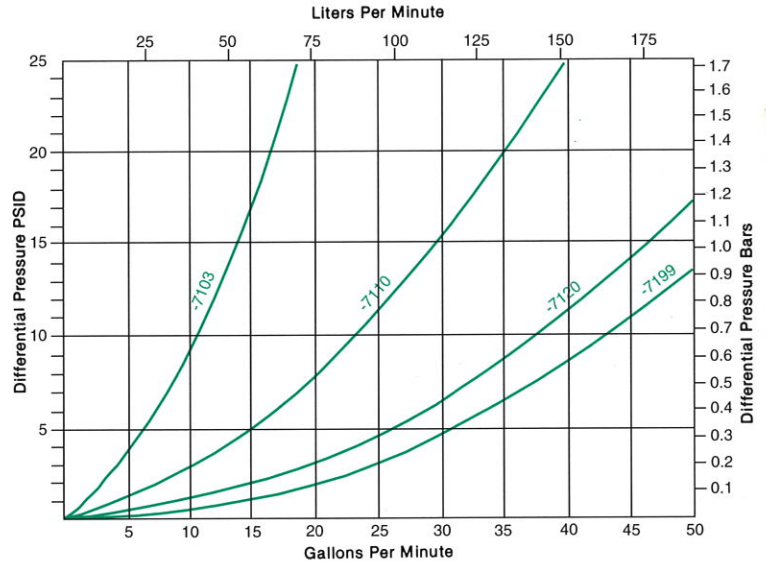

Graph 2. Pressure Drop Versus Flow
 Extended Length Cartridge
 296201-0000/457217-(Below)

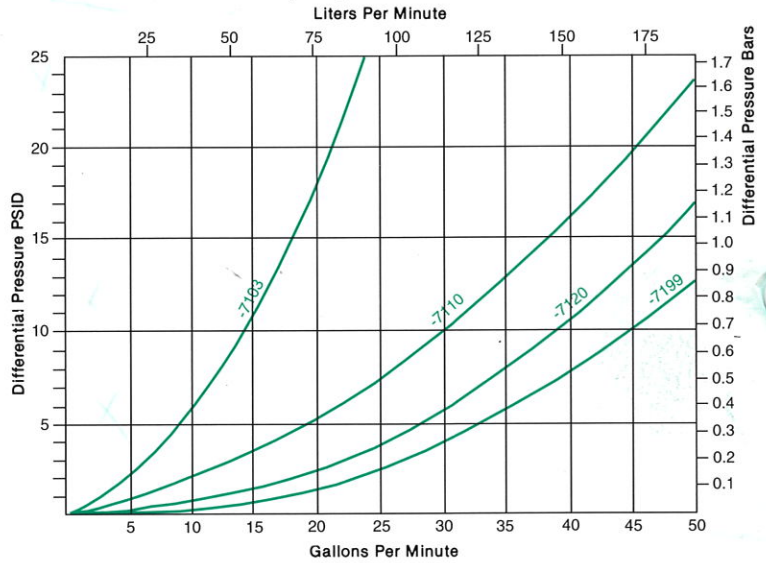

Graph 3. By-Pass Valve Data
 Note: Dual Scale Ordinate

For Units Having 25-50 PSID
 By-Pass Valves Add Curve 4
 of Graph 3 to Pressure Drop
 In Graphs. 1 and 2

Curve 1 Flow Thru 25 PSID Crack By-Pass at 600 SUS
 Curve 2 Flow Thru 25 PSID Crack By-Pass at 225 SUS
 Curve 3 Flow Thru 25 PSID Crack By-Pass at 100 SUS
 Curve 4 Additional Pressure Drop Due to 25 to 50 PSID By-Pass Valves

